



MAX8738 Evaluation Kit

General Description

The MAX8738 evaluation kit (EV kit) is a fully assembled and tested circuit board that evaluates the MAX8738 programmable VCOM-adjustment solution for thin-film transistor (TFT), liquid-crystal displays (LCDs). The EV kit is designed to be used as a replacement for the labor-intensive VCOM-adjustment process usually done by setting potentiometers mechanically. The EV kit includes an optical encoder and a pushbutton that are used to adjust the VCOM voltage and save this voltage setting into the MAX8738's internal EEPROM.

**Purchase of I²C components from Maxim Integrated Products, Inc., or one of its sublicensed Associated Companies, conveys a license under the Philips I²C Patent Rights to use these components in an I²C system, provided that the system conforms to the I²C Standard Specification as defined by Philips.*

Features

- ◆ Proven PC Board Layout
- ◆ Optical Encoder for Easy VCOM Adjustments
- ◆ Restores VCOM Settings on Power-Up
- ◆ Momentary Pushbutton for Internal EEPROM Programming
- ◆ LEDs for User Feedback
- ◆ Terminals for External I²C* Bus Control
- ◆ Fully Assembled and Tested

Ordering Information

PART	TEMP RANGE	IC PACKAGE
MAX8738EVKIT	0°C to +70°C	8 μMAX

Component List

DESIGNATION	QTY	DESCRIPTION
C1	1	0.01μF ±10%, X7R 50V capacitor (0603) TDK C1608X7R1H103K
C2–C9	8	0.1μF ±10%, X7R 50V capacitors (0603) TDK C1608X7R1H104K
C10	1	10μF ±20%, 10V capacitor (1206) TDK X5R C3216X5R1A106M
C11	1	2.2μF ±10%, X7R 25V capacitor (1206) TDK C3216X7R1E225K
C12, C13	2	18pF ±5%, 50V C0G capacitors (0603) TDK C1608C0G1H180J
D1–D4	4	Green LEDs Kingbright L934GT
J1	1	2 x 5 right-angle receptacle (2mm) Sullins PPWN052FJFN
R1, R2	2	3.9kΩ ±5% resistors (0603)
R3	1	24.9kΩ ±1% resistor (0805)
R4	1	51.1kΩ ±1% resistor (0805)
R5	1	64.9kΩ ±1% resistor (0805)
R6, R7	2	8.2kΩ ±5% resistors (0603)

DESIGNATION	QTY	DESCRIPTION
R8–R11	4	150Ω ±5% resistors (0603)
R12–R15	4	10kΩ ±5% resistors (0603)
R16	1	10Ω ±5% resistor (0603)
SW1	1	32-position optical encoder Grayhill 61C11-01-08-01
SW2	1	Momentary pushbutton switch OMRON B3S-1000
U1	1	TFT LCD calibrator (I ² C interface) MAX8738EUA (8-pin μMax)
U2	1	Ultra-high-speed microcontroller DS89C420-ECL (44-pin TQFP)
U3	1	300mA, LDO, 3.3V regulator MAX8887EZK33-T (5-pin SOT23)
Y1	1	6MHz crystal Citizen HC49US6.000MABJ
None	1	MAX8738 EV kit PC board

Evaluates: MAX8738

MAX8738 Evaluation Kit

Component Suppliers

SUPPLIER	PHONE	WEBSITE
Citizen	949-428-3700	www.citizenocrystal.com
TDK	847-803-6100	www.component.tdk.com

Note: Indicate you are using the MAX8738 when contacting these component suppliers.

Quick Start

Recommended Equipment

- 3 power supplies:
 - a) 16.1V or higher (up to 28V) at 10mA for VGON
 - b) 9V at 10mA for AVDD
 - c) 5V at 250mA for VCC
- 1 digital voltmeter (DVM)

Procedure

Do not turn on the power supplies until all connections are made:

- 1) Connect the 5V power supply between the VCC and GND pads.
- 2) Connect the 16.1V or higher power supply between the VGON and GND pads.
- 3) Connect the 9V power supply between the AVDD and GND pads.
- 4) Turn on all three power supplies.
- 5) Measure the voltage at VOUT. It should be approximately 3.73V.

Detailed Description

The MAX8738 evaluation kit (EV kit) is a fully assembled and tested circuit board that evaluates the MAX8738 programmable VCOM-adjustment solution for TFT LCDs. On the PC board, the unbuffered VCOM adjustment signal (VOUT) is available on the VOUT pad.

The EV kit is designed to output a typical VOUT voltage between 3.48V and 3.97V (with AVDD at 9V) with 7-bit resolution. For this, the AVDD voltage should be 9V. If a different VOUT range is desired or if a different AVDD voltage is used, the user may need to change R3, R4, and R5. The pads for these resistors are designed for standard 0805 case sizes. Refer to the *Setting the VCOM Adjustment Range* section in the MAX8738 data sheet for instructions about how to select these resistors.

Note that the VGON input voltage must be between 16.1V and 28V to supply the high voltage needed for internal EEPROM programming.

An optical encoder (SW1) is used to send VCOM adjustment commands to the MAX8738. When the user turns the knob on the optical encoder, the on-board microcontroller (U2) sends an I²C command byte (0xFF or 0x00) to the MAX8738. Turning the knob clockwise decreases the VOUT voltage, while turning the knob counterclockwise increases the VCOM voltage. As the knob on the optical encoder is turned, a different LED lights indicating the direction of change of the VOUT voltage.

The momentary pushbutton switch (SW2) on the EV kit is used to save the MAX8738's DAC setting to its internal EEPROM. When the button is pressed, the on-board microcontroller (U2) sends an I²C command byte (0xAA) to the MAX8738. The LEDs flash on and off quickly, indicating that the DAC setting has been saved.

The MAX8738 supports additional I²C command bytes not supported by this EV kit such as 0x55 (reload DAC setting from EEPROM) and 0x11 (program-specific value of the DAC). The SDA and SCL pads on the EV kit can be used to connect to an I²C controller where these commands (or any of the commands supported by the MAX8738) can be transmitted.

MAX8738 Evaluation Kit

Evaluates: MAX8738

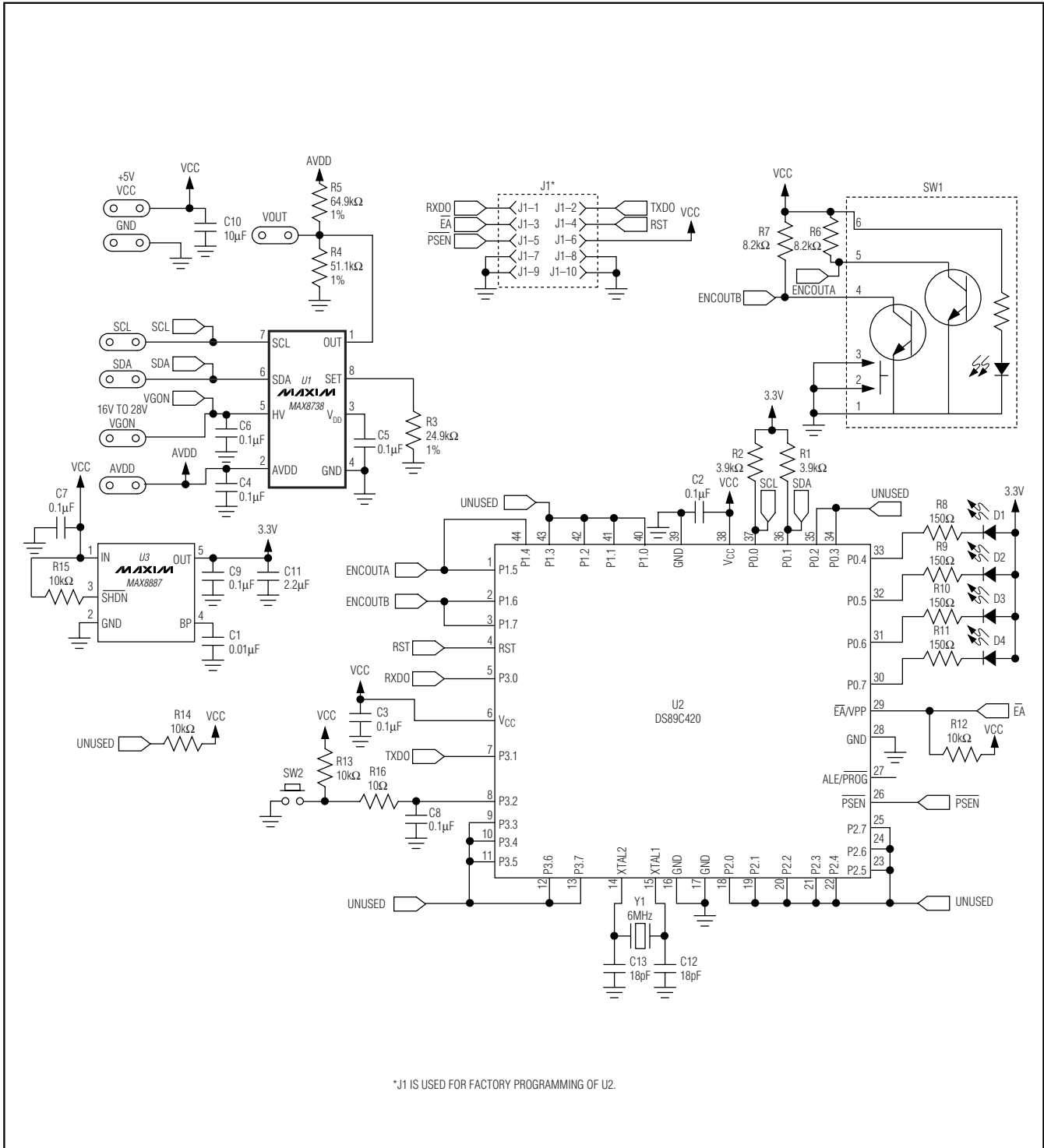

Figure 1. MAX8738 EV Kit Schematic

MAX8738 Evaluation Kit

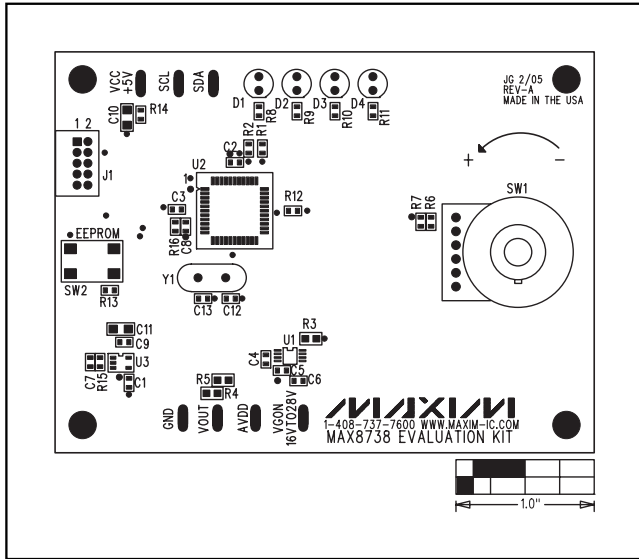

Figure 2. MAX8738 EV Kit Component Placement Guide—Component Side

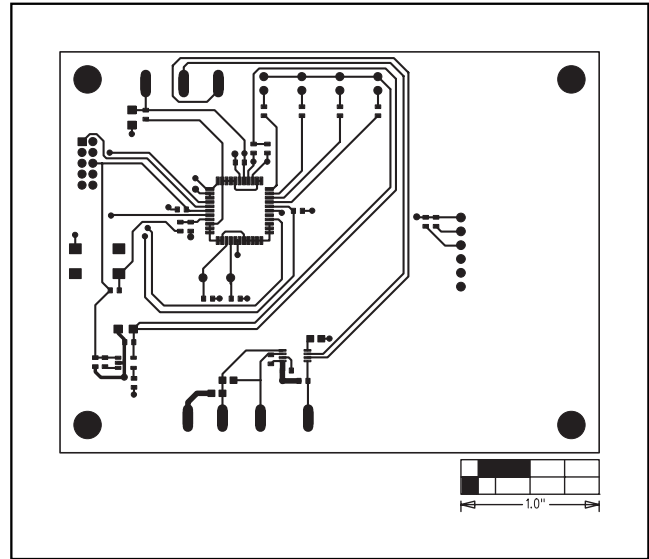

Figure 3. MAX8738 EV Kit PC Board Layout—Component Side

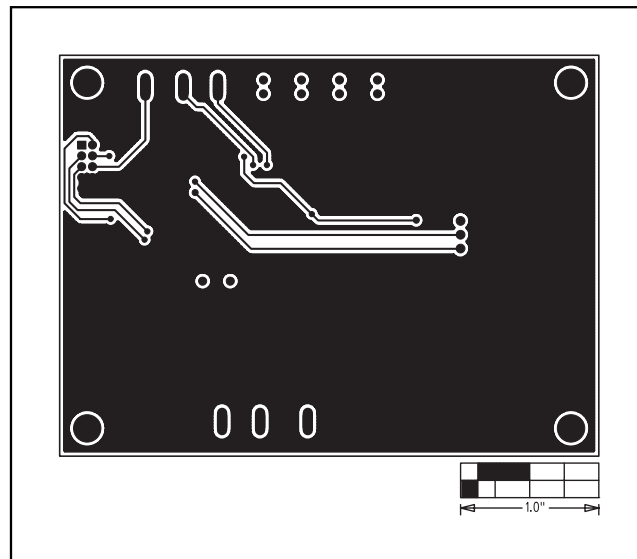

Figure 4. MAX8738 EV Kit PC Board Layout—Solder Side

Maxim cannot assume responsibility for use of any circuitry other than circuitry entirely embodied in a Maxim product. No circuit patent licenses are implied. Maxim reserves the right to change the circuitry and specifications without notice at any time.

4 **Maxim Integrated Products, 120 San Gabriel Drive, Sunnyvale, CA 94086 408-737-7600**